

FEMALE END VIEW

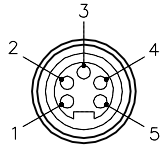

- 1 = BARE (SHIELD)
- 2 = RED (+ VOLTAGE)
- 3 = BLACK (- VOLTAGE)
- 4 = WHITE (CAN_H)
- 5 = BLUE (CAN_L)

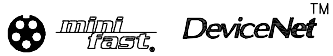

SPECIFICATIONS

CONTACT CARRIER MATERIAL	TPU
MOLDED HEAD MATERIAL/COLOR	TPU/BLUE-GRAY
CONTACT MATERIAL/PLATING	BRASS/GOLD
COUPLING NUT MATERIAL/FINISH	STAINLESS STEEL/PASSIVATED
RATED CURRENT [A]	4.0 A
RATED VOLTAGE [V]	300 V
CABLE JACKET MATERIAL/COLOR	TPU/VIOLET (HALOGEN FREE)
CONDUCTOR INSULATION MATERIAL	POLYOLEFIN (22 AWG), POLYETHYLENE (24 AWG)
NUMBER OF CONDUCTORS [AWG]	2x22 AWG, 2x24 AWG, 22 AWG DRAIN
SHIELDING	ALUM. FOIL (PAIRS), TINNED-COPPER BRAID (OVERALL)
TEMPERATURE RATING	-40°C to +80°C (-40°F to +176°F)
PROTECTION CLASS	MEETS NEMA 1,3,4,6P AND IEC IP67

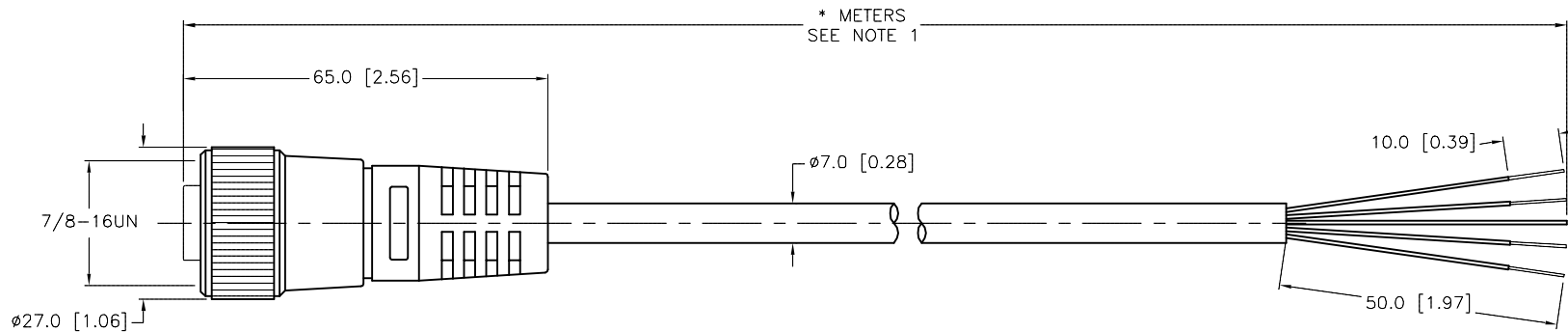

CABLE LENGTH	TOLERANCE *
ALL LENGTHS	+ 4% (OR 50mm) OF LENGTH - 0% (OR 0mm) OF LENGTH WHICHEVER IS GREATER
STRIP LENGTH	TOLERANCE *
0-7mm	±0.5mm
8-29mm	±1.0mm
30-49mm	±2.0mm
50-69mm	±3.0mm
70-100mm	±4.0mm
OVER 100mm	±5.0mm

* UNLESS OTHERWISE SPECIFIED

SOURCE DRAWING - FOR REFERENCE ONLY

NOTES:

1. "*" INDICATES CABLE LENGTH IN METERS. CONTACT TURCK TO ORDER SPECIFIC LENGTHS.

RELATED DOCUMENTS 1. 2. 3. 4.	3RD ANGLE PROJECTION 	THIS DRAWING IS CONFIDENTIAL AND THE PROPERTY OF TURCK INC. USE OF THIS DOCUMENT WITHOUT WRITTEN PERMISSION IS PROHIBITED.		3000 CAMPUS DRIVE MINNEAPOLIS, MN 55441 1-800-544-7769 (763) 553-7300 (763) 553-0708 fax turck.com	
		DRFT CK	DATE 05/06/11	DESCRIPTION RKV 5725-*M	
MATERIAL SEE SPECIFICATIONS	ALL DIMENSIONS DISPLAYED ON THIS DRAWING ARE FOR REFERENCE ONLY	APVD	SCALE 1=1.3	IDENTIFICATION NO.	
FINISH SEE SPECIFICATIONS		UNIT OF MEASUREMENT MILLIMETER [INCH]		REV E	
		DO NOT SCALE THIS DRAWING		FILE: 777027652	SHEET 1 OF 1

E	UPDATE RATED CURRENT	RDS	06/13/14	46093
REV	DESCRIPTION	BY	DATE	ECO NO.